

General Description

The SA52631 is a high voltage floating driver for directly driving high side and low side channels. The floating channel can be used to drive 40V N-channel MOSFET in high side configuration. Input logic is compatible with standard CMOS or TTL. Compact SOP8 package is utilized to minimize the peripheral circuit design and the difficulty of PCB mounting.

Ordering Information

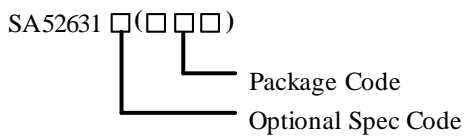

Ordering Number	Package type	Note
SA52631FAP	SOP8	

Features

- High Voltage Range up to 40 V
- 0.75A Source and 1.25A Sink Current
- VCC Operation Range from 4.4V to 14V
- CMOS/TTL Compatible
- Fast Propagation Delay Time
- SOP8 Package
- AEC-Q100 Qualified

Applications

- Wireless Charger
- Half-bridge Gate Driver

Typical Application

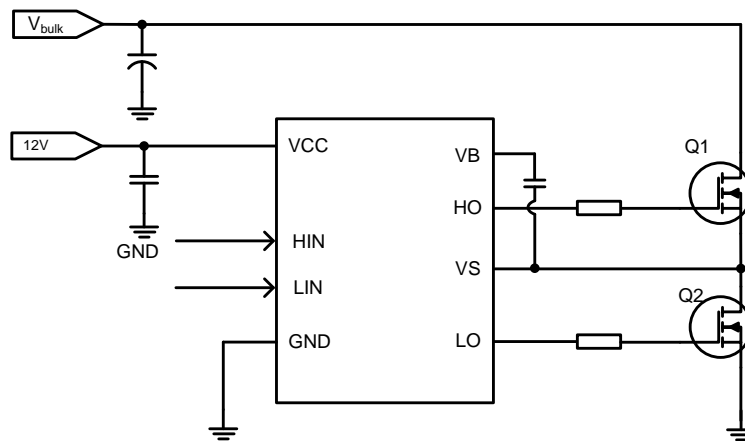
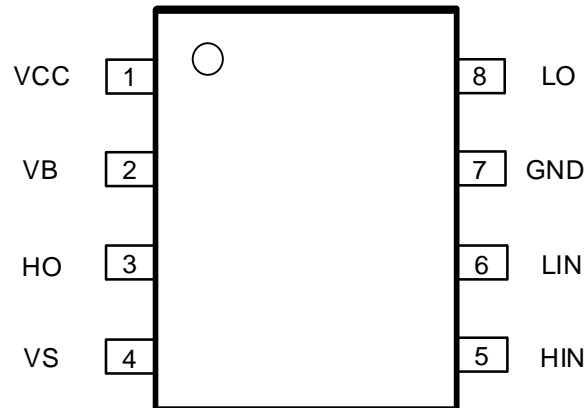

Figure 1. SA52631 Application Schematic

Pinout (Top View)



(SOP8)

Top Mark: GGG xyz (device code: GGG, *x*=year code, *y*=week code, *z*=lot number code)

Pin Name	Pin No.	Pin Description
VCC	1	Logic power supply pin. Decouple with MLCC to ground for high frequency noise elimination.
VB	2	High-side bias voltage supply pin.
HO	3	High-side driver output pin.
VS	4	High-side bias voltage floating ground.
HIN	5	High-side control signal input pin.
LIN	6	Low-side control signal input pin.
GND	7	Logic ground.
LO	8	Low-side driver output pin.

Function Block

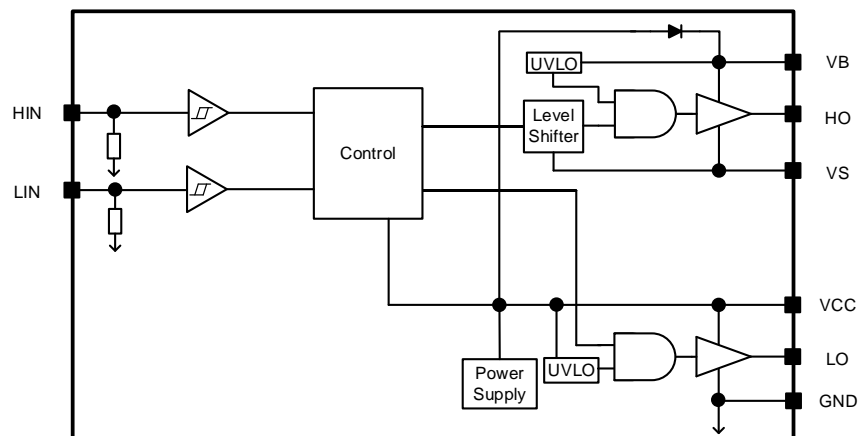

Figure 2. Block Diagram



Absolute Maximum Ratings (Note 1)

V _{CC} -----	-0.3- 20V
V _{VB} -----	-0.3-44V
V _{VS} -----	-1V - V _{VB} +0.3V
V _{HIN} , V _{LIN} -----	-0.3- +20V
V _{HO} -----	V _{VS} -0.3V - V _{VB} +0.3V
V _{LO} -----	-0.3V - V _{CC} +0.3V
Power Dissipation, P _D @ T _A = 25°C, -----	0.21 W
Package Thermal Resistance (Note 2)	
θ _{JA} -----	35 °C/W
θ _{JC} -----	33 °C/W
Junction Temperature Range -----	-40°C to +150°C
Storage Temperature Range -----	-65°C to 150°C

Recommended Operating Conditions

V _{CC} -----	+4.4V to +14V
V _{VB} -----	V _{VS} +4.4V to V _{VS} +14V
V _{VS} (Note 3) -----	-1V to +40V
V _{HIN} , V _{LIN} -----	0V to +5V
dV _S /dt -----	less than 50V/ns
Operation Junction Temperature Range -----	-40°C to +125°C

Electrical Characteristics

$T_A=T_J=-40^{\circ}\text{C}$ to 125°C , $V_{CC}=V_{VB}=12\text{V}$, no load on LO and HO, unless otherwise specified.

Parameter	Symbol	Test Conditions	Min.	Typ.	Max.	Units
Supply Current						
Quiescent V_{CC} Supply Current	I_{QVCC}	$V_{HIN}=V_{LIN}=0\text{V}$		70	110	μA
Operation V_{CC} Supply Current	I_{OPVCC}	$f=200\text{kHz}$, $C_{LOAD}=1000\text{pF}$		3		mA
Quiescent V_{BS} Supply Current (Note 4)	I_{QVBS}	$V_{HIN}=V_{LIN}=0\text{V}$		65	100	μA
Operation V_{BS} Supply Current	I_{OPVBS}	$f=200\text{kHz}$, $C_{LOAD}=1000\text{pF}$		3		mA
Input Signal						
Logic “1” Input Voltage	V_{IH}		2.4			V
Logic “0” Input Voltage	V_{IL}				0.8	V
Input Hysteresis	V_{IHYS}			680		mV
Logic “1” Input Bias Current	I_{IH}	$V_{IN}=5\text{V}$			50	μA
Logic “0” Input Bias Current	I_{IL}	$V_{IN}=0\text{V}$			5	μA
Under Voltage Lock Out						
V_{CC} under Voltage Rising Threshold	V_{CCUV+}		3.6	4	4.4	V
V_{CC} under Voltage Falling Threshold	V_{CCUV-}		3.1	3.5	3.9	V
V_{BS} under Voltage Rising Threshold	V_{BSUV+}		3.6	4	4.4	V
V_{BS} under Voltage Falling Threshold	V_{BSUV-}		3.1	3.5	3.9	V
Boot Strap Diode						
Low Current forward Voltage	V_{F1}	$I_{VCC-VB}=100\mu\text{A}$		0.65		V
High Current forward Voltage	V_{F2}	$I_{VCC-VB}=100\text{mA}$		0.9		V
Gate Driver						
High-side High Level Output Voltage	V_{HOH}	$I_O=-100\text{mA}$, $V_{HOH}=V_{VB}-V_{HO}$		0.71		V
High-side Low Level Output Voltage	V_{HOL}	$I_O=100\text{mA}$		0.21		V
Low-side High Level Output Voltage	V_{LOH}	$I_O=-100\text{mA}$, $V_{LOH}=V_{CC}-V_{LO}$		0.71		V
Low-side Low Level Output Voltage	V_{LOL}	$I_O=100\text{mA}$		0.21		V
Gate Driver Output						
Peak Pull-up Current	I_{O-}	$V_O=0\text{V}$, (Note 5)		0.75		A
Peak Pull-down Current	I_{O+}	$V_O=12\text{V}$, (Note 5)		1.25		A

Note 1: Stresses listed as the above “Absolute Maximum Ratings” may cause permanent damage to the device. These are for stress ratings. Functional operation of the device at these or any other conditions beyond those indicated in the operational sections of the specifications is not implied. Exposure to absolute maximum rating conditions for extended periods may remain possibility to affect device reliability.

Note 2: θ_{JA} is measured in the natural convection at $T_A = 25^{\circ}\text{C}$ on a high effective 4-layer thermal conductivity test board with four thermals via.

Note 3: Make sure V_{VB} does not exceed ABS 44V.

Note 4: $V_{BS}=V_{VB}-V_{VS}$

Note 5: This spec is guaranteed by design.

Propagation Delays

$V_{CC}=V_{BS}=12V$, $V_S=GND=0V$, $C_L=1000pF$, $T_A=25^{\circ}C$, unless otherwise specified.

Parameter	Symbol	Test Conditions	Min.	Typ.	Max.	Units
Turn on Propagation Delay	T_{DLTON}			32		ns
Turn off Propagation Delay	T_{DLTOFF}			27		ns

Delay Matching

$V_{CC}=V_{BS}=12V$, $V_S=GND=0V$, $C_L=1000pF$, $T_A=25^{\circ}C$, unless otherwise specified.

Parameter	Symbol	Test Conditions	Min.	Typ.	Max.	Units
Delay Matching, HO&LO Turn-on	T_{MON}				10	ns
Delay Matching, HO&LO Turn-off	T_{MOFF}				10	ns

Output Rising and Falling Time

$V_{CC}=V_{BS}=12V$, $V_S=GND=0V$, $T_A=25^{\circ}C$, unless otherwise specified.

Parameter	Symbol	Test Conditions	Min.	Typ.	Max.	Units
Turn on Rise Time	t_R	$C_{LOAD} = 1000pF$, from 10% to 90%		20		ns
Turn off Fall Time	t_F			10		ns

Switching Timing

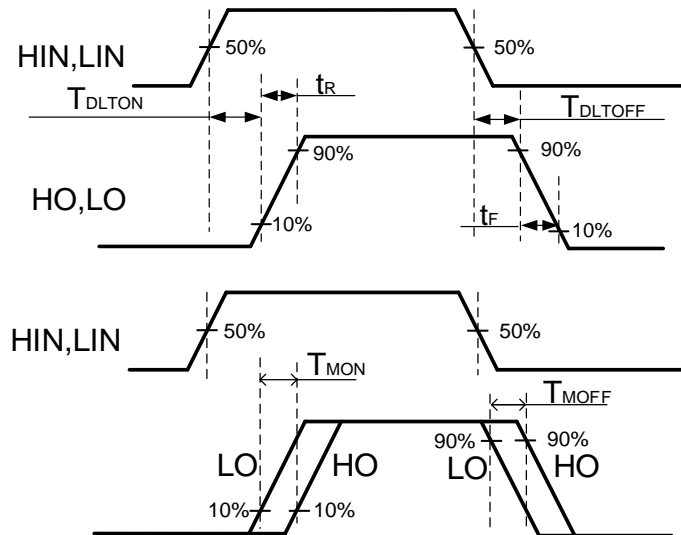
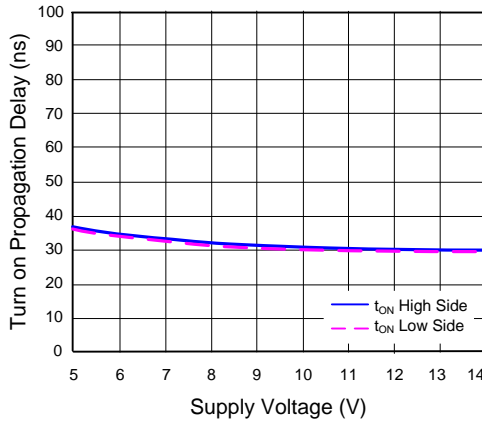

Figure 3. Timing Diagram

Typical Performance Characteristics

Turn on Propagation Delay vs. Supply Voltage



Turn on Propagation Delay vs. Temperature

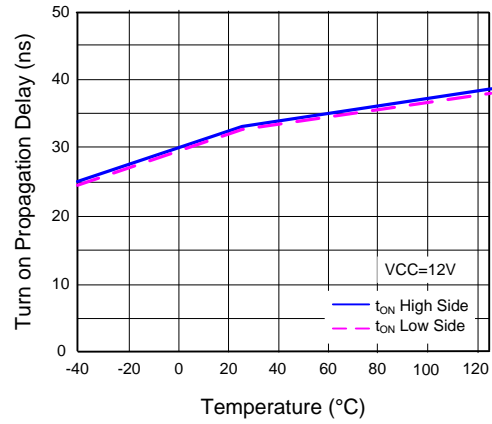

Turn off Propagation Delay vs. Supply Voltage

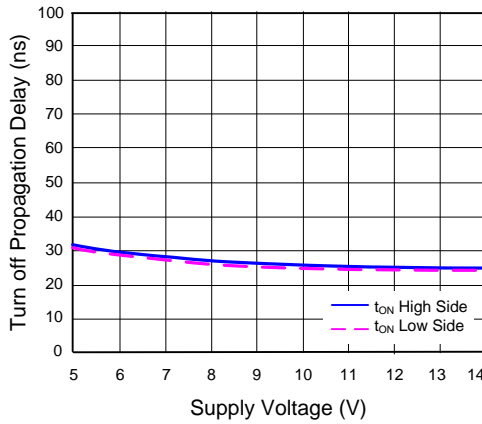

Turn off Propagation Delay vs. Temperature

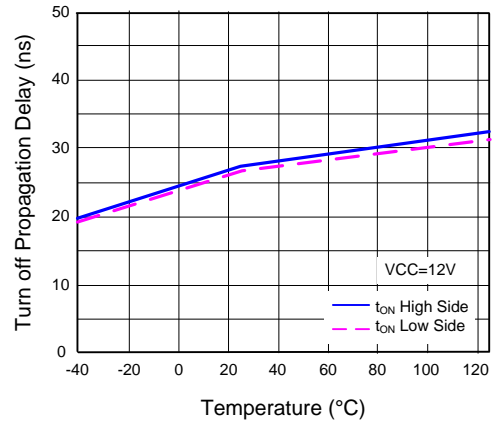

Rise Time vs. Supply Voltage

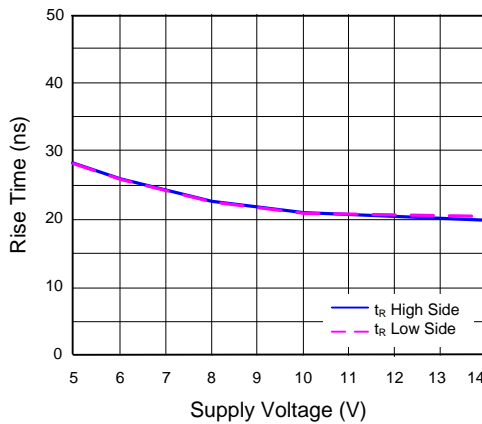

Rise Time vs. Temperature

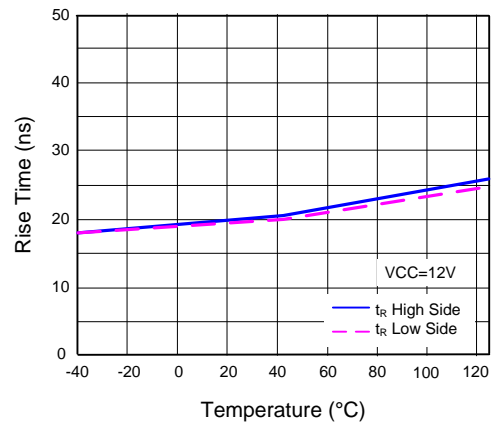

Fall Time vs. Supply Voltage

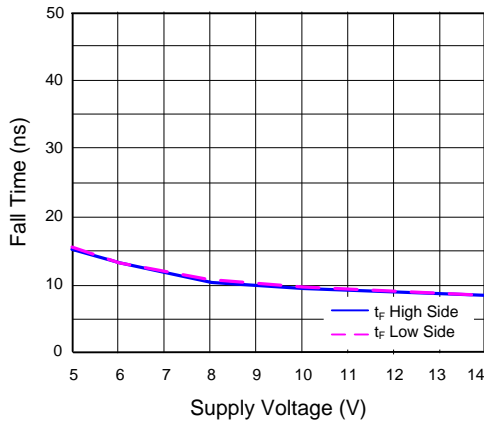

Fall Time vs. Temperature

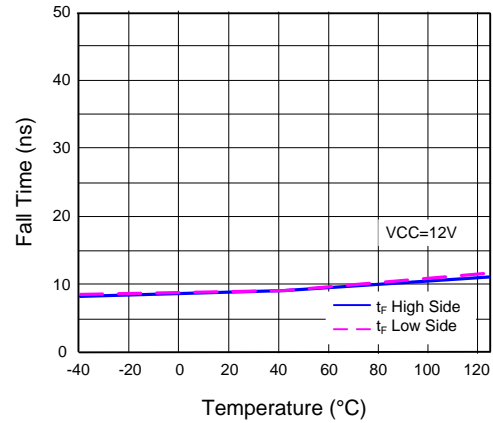

Quiescent Current vs. Supply Voltage

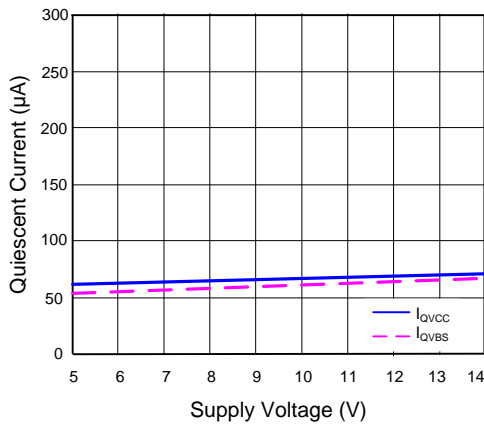

Quiescent Current vs. Temperature

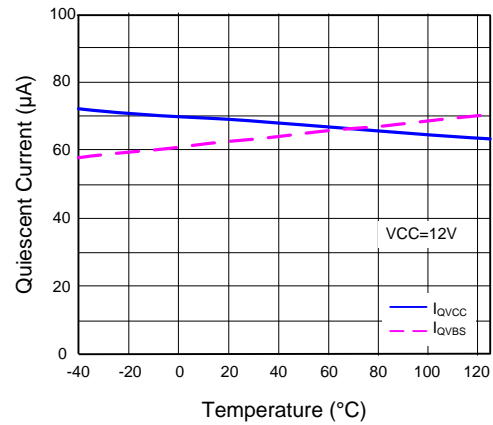

Delay Matching vs. Supply Voltage

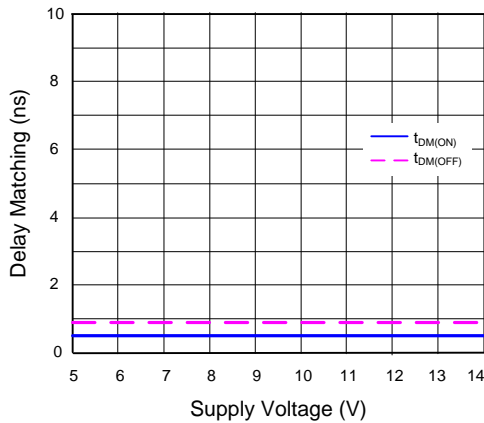

Delay Matching vs. Temperature

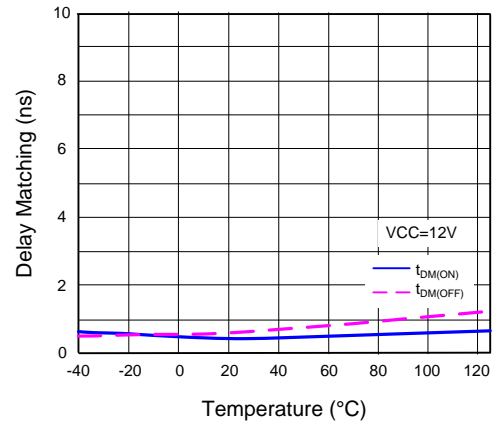

Output Source Current vs. Supply Voltage

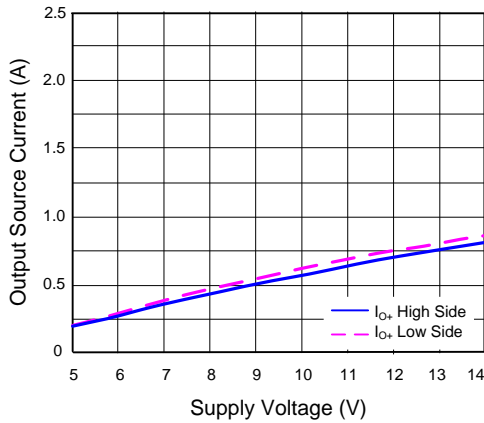

Output Source Current vs. Temperature

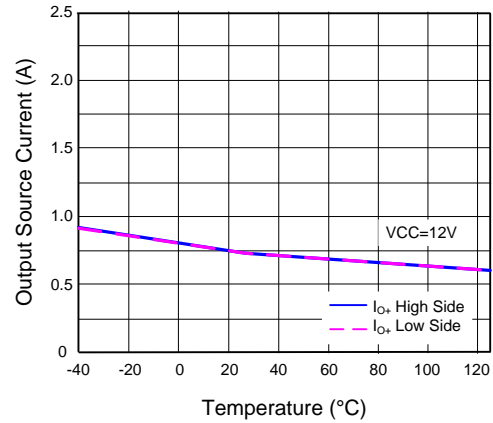

Output Sink Current vs. Supply Voltage

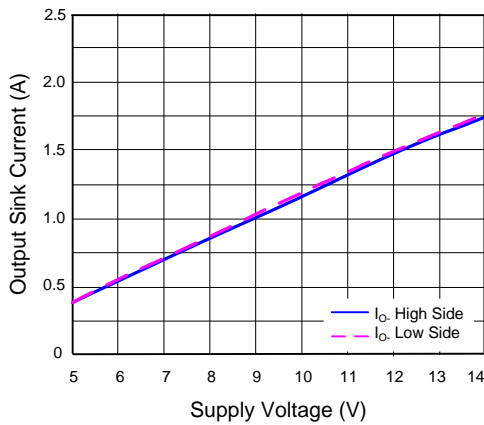

Output Sink Current vs. Temperature

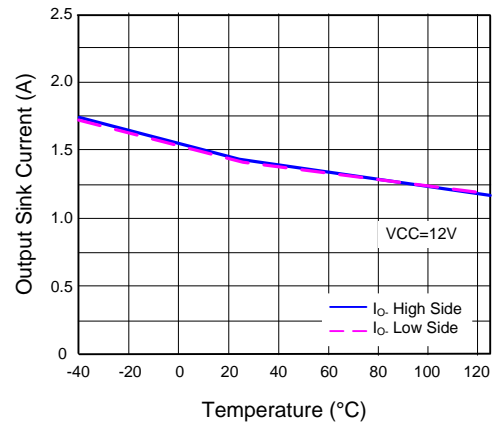

Logic 1 Input Voltage vs. Supply Voltage

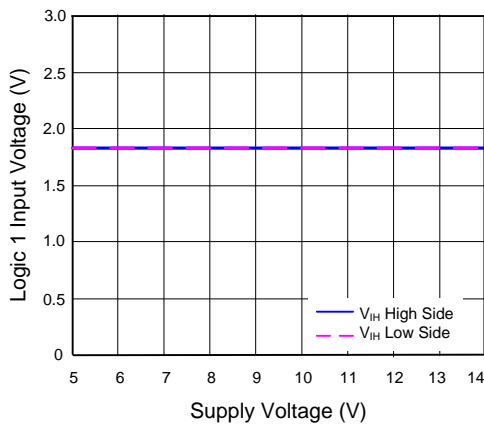

Logic 1 Input Voltage vs. Temperature

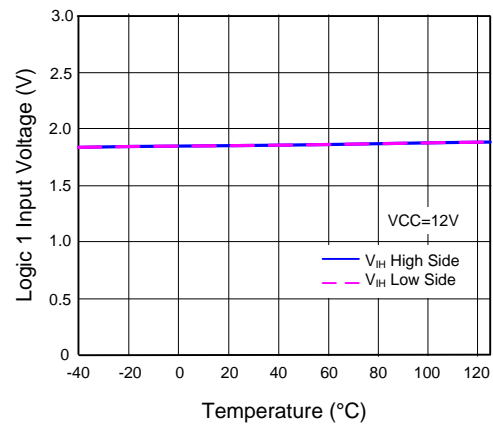

Logic 0 Input Voltage vs. Supply Voltage

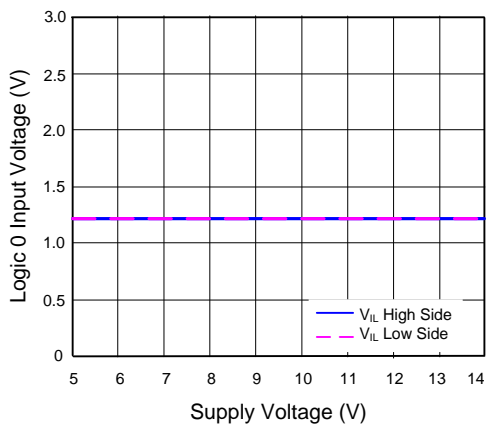

Logic 0 Input Voltage vs. Temperature

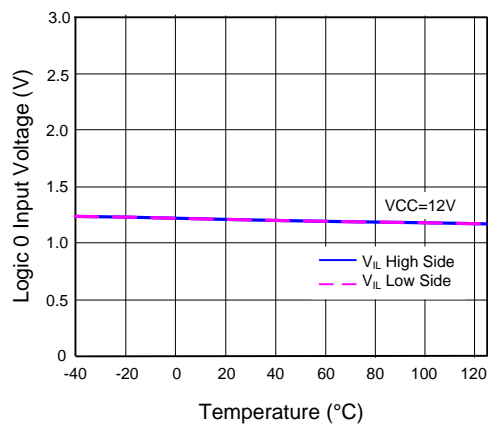

Function Description

Logic Truth Table

The output state is dependent on the states of the HIN and LIN states.

Table 1. Logic Truth Table

HIN	LIN	HO	LO
L	L	L	L
L	H	L	H
H	L	H	L
H	H	L	L

Under Voltage Protection

The SA52631 provides undervoltage protection on both the V_{CC} and the V_{BS} power supply. If at any time the voltage on VCC pin falls below the undervoltage lockout threshold voltage, all circuitry in the device will be disabled, and all internal logic will be reset. If at any the voltage on VBS falls below the undervoltage lockout threshold voltage, the circuitry in high side will be disabled. Operation will resume when VCC or VBS pin voltage rises above the UVLO threshold.

Shoot Through Protection

The SA52631 is equipped with shoot-through protection circuitry. When both the high-side and low-side switches are conducted at the same time, the IC disables all the output.

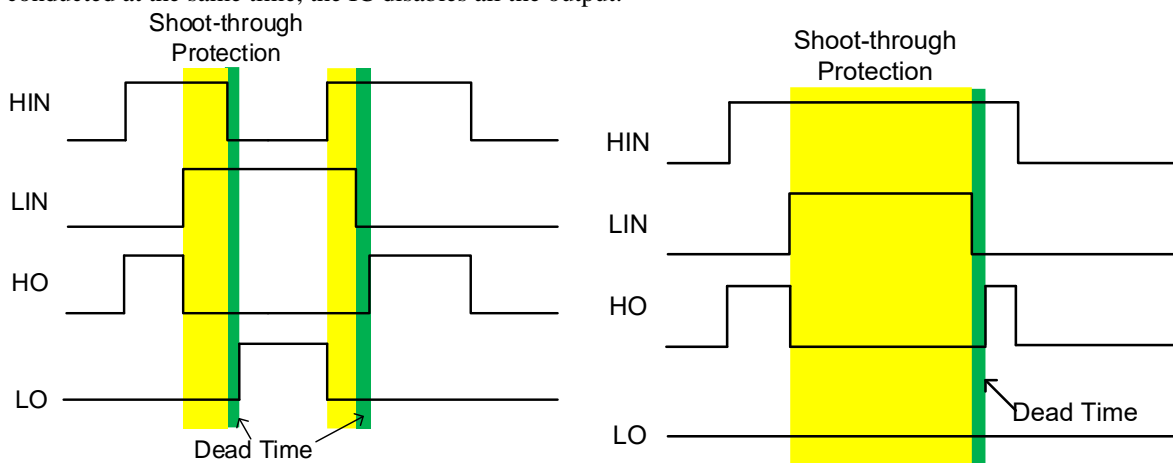
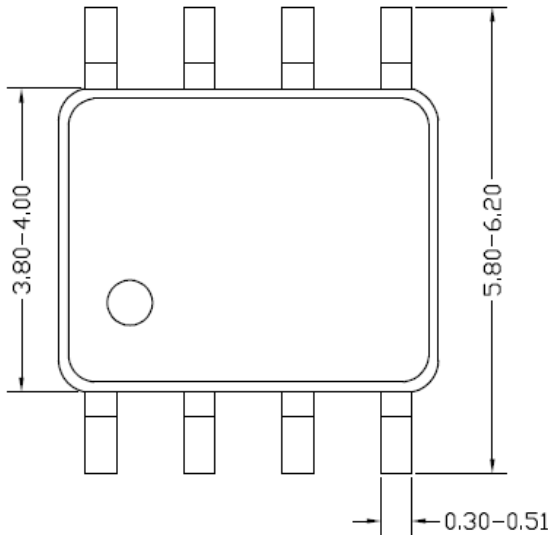
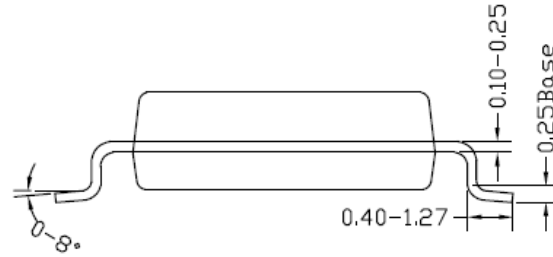

Figure 4. Shoot-through Protection

SOP8 Package Outline Drawing & PCB Layout Design



Top view



Bottom view

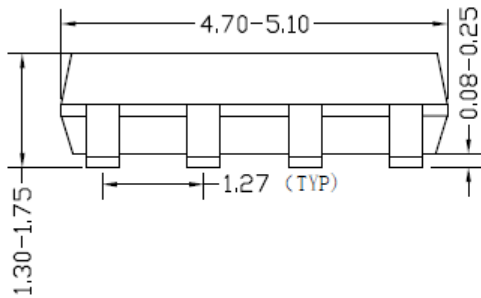

Front view

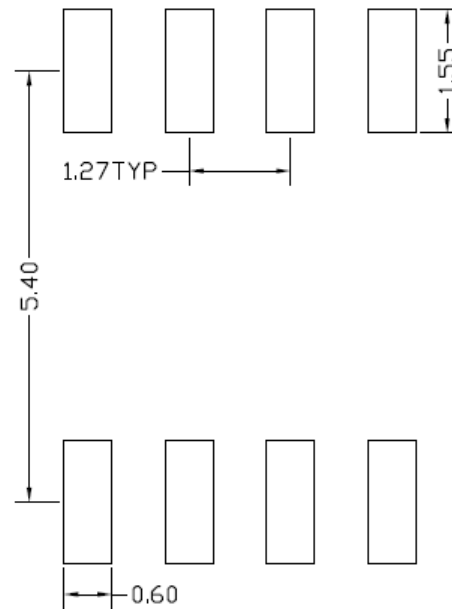

**Recommended PCB layout
(Reference only)**

Notes: All dimension in millimeter and exclude mold flash & metal burr.

Taping & Reel Specification

1. Taping Orientation for Packages (SOP8)

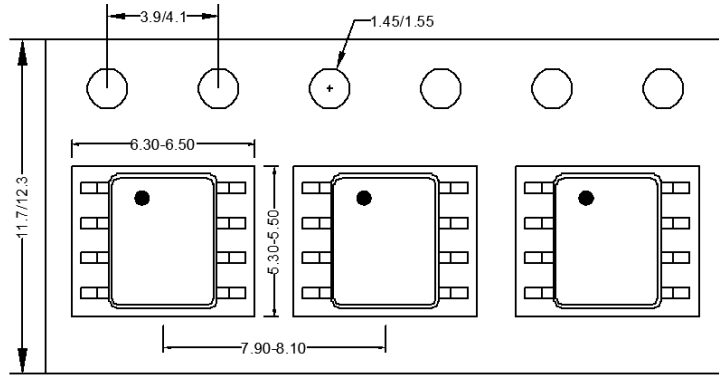

Feeding direction →

2. Carrier Tape & Reel Specification for Packages

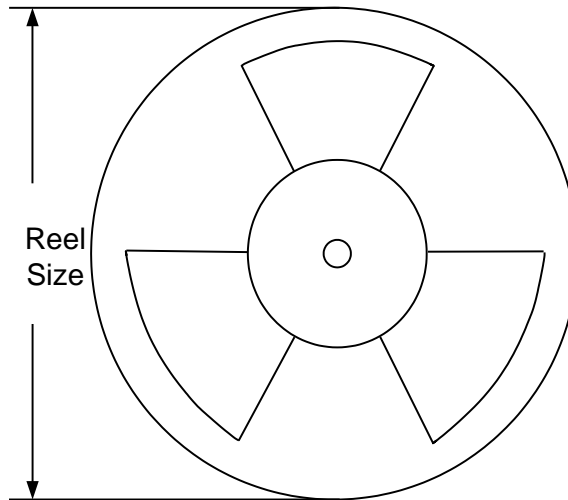

Package Type	Tape Width (mm)	Pocket Pitch(mm)	Reel Size (Inch)	Trailer Length(mm)	Leader Length (mm)	Qty per Reel
SOP8	12	8	13"	400	400	2500

3. Others: NA



Revision History

The revision history provided is for informational purpose only and is believed to be accurate, however, not warranted. Please make sure that you have the latest revision.

Revision Number	Revision Date	Description
0.9	September 25, 2023	Initial Release
1.0	September 25, 2024	Production Release



IMPORTANT NOTICE

- 1. Right to make changes.** Silergy and its subsidiaries (hereafter Silergy) reserve the right to change any information published in this document, including but not limited to circuitry, specification and/or product design, manufacturing or descriptions, at any time and without notice. This document supersedes and replaces all information supplied prior to the publication hereof. Buyers should obtain the latest relevant information before placing orders and should verify that such information is current and complete. All semiconductor products are sold subject to Silergy's standard terms and conditions of sale.
- 2. Applications.** Application examples that are described herein for any of these products are for illustrative purposes only. Silergy makes no representation or warranty that such applications will be suitable for the specified use without further testing or modification. Buyers are responsible for the design and operation of their applications and products using Silergy products. Silergy or its subsidiaries assume no liability for any application assistance or designs of customer products. It is customer's sole responsibility to determine whether the Silergy product is suitable and fit for the customer's applications and products planned. To minimize the risks associated with customer's products and applications, customer should provide adequate design and operating safeguards. Customer represents and agrees that it has all the necessary expertise to create and implement safeguards which anticipate dangerous consequences of failures, monitor failures and their consequences, lessen the likelihood of failures that might cause harm and take appropriate remedial actions. Silergy assumes no liability related to any default, damage, costs or problem in the customer's applications or products, or the application or use by customer's third-party buyers. Customer will fully indemnify Silergy, its subsidiaries, and their representatives against any damages arising out of the use of any Silergy components in safety-critical applications. It is also buyers' sole responsibility to warrant and guarantee that any intellectual property rights of a third party are not infringed upon when integrating Silergy products into any application. Silergy assumes no responsibility for any said applications or for any use of any circuitry other than circuitry entirely embodied in a Silergy product.
- 3. Limited warranty and liability.** Information furnished by Silergy in this document is believed to be accurate and reliable. However, Silergy makes no representation or warranty, expressed or implied, as to the accuracy or completeness of such information and shall have no liability for the consequences of use of such information. In no event shall Silergy be liable for any indirect, incidental, punitive, special or consequential damages, including but not limited to lost profits, lost savings, business interruption, costs related to the removal or replacement of any products or rework charges, whether or not such damages are based on tort or negligence, warranty, breach of contract or any other legal theory. Notwithstanding any damages that customer might incur for any reason whatsoever, Silergy' aggregate and cumulative liability towards customer for the products described herein shall be limited in accordance with the Standard Terms and Conditions of Sale of Silergy.
- 4. Suitability for use.** Customer acknowledges and agrees that it is solely responsible for compliance with all legal, regulatory and safety-related requirements concerning its products, and any use of Silergy components in its applications, notwithstanding any applications-related information or support that may be provided by Silergy. Silergy products are not designed, authorized or warranted to be suitable for use in life support, life-critical or safety-critical systems or equipment, nor in applications where failure or malfunction of a Silergy product can reasonably be expected to result in personal injury, death or severe property or environmental damage. Silergy assumes no liability for inclusion and/or use of Silergy products in such equipment or applications and therefore such inclusion and/or use is at the customer's own risk.
- 5. Terms and conditions of commercial sale.** Silergy products are sold subject to the standard terms and conditions of commercial sale, as published at <http://www.silergy.com/stdterms>, unless otherwise agreed in a valid written individual agreement specifically agreed to in writing by an authorized officer of Silergy. In case an individual agreement is concluded only the terms and conditions of the respective agreement shall apply. Silergy hereby expressly objects to and denies the application of any customer's general terms and conditions with regard to the purchase of Silergy products by the customer.
- 6. No offer to sell or license.** Nothing in this document may be interpreted or construed as an offer to sell products that is open for acceptance or the grant, conveyance or implication of any license under any copyrights, patents or other industrial or intellectual property rights. Silergy makes no representation or warranty that any license, either express or implied, is granted under any patent right, copyright, mask work right, or other intellectual property right. Information published by Silergy regarding third-party products or services does not constitute a license to use such products or services or a warranty or endorsement thereof. Use of such information may require a license from a third party under the patents or other intellectual property of the third party, or a license from Silergy under the patents or other intellectual property of Silergy.

For more information, please visit: www.silergy.com

© 2023 Silergy Corp.

All Rights Reserved.