

### General Description

The SY59525 is the low side LLC controller integrated with a 650V MOSFET, it is used in charge pump PFC application. The high PF is achieved by inherent PFC function and the low LED current ripple is achieved by LLC topology. The single stage structure and primary side regulation save the BOM cost a lot. Meanwhile, the LLC topology improves the efficiency and EMI.

The SY59525 should work with SY59526, which is the high side LLC controller integrated with a 650V MOSFET.

### Features

- Integrated 650V MOSFET
- Charge Pump PFC LLC Topology with Low BOM Cost
- PF>0.95, THD<20%
- Primary Side I<sub>LED</sub> Regulation and Less than 2% I<sub>LED</sub> Ripple
- Short LED Protection (SLP), Open LED Protection (OLP), E-cap over Voltage Protection (HV OVP)
- Zero Voltage Overshoot on Resonant Capacitor at Startup
- Compact Package: SO8

### Applications

- LED Lighting

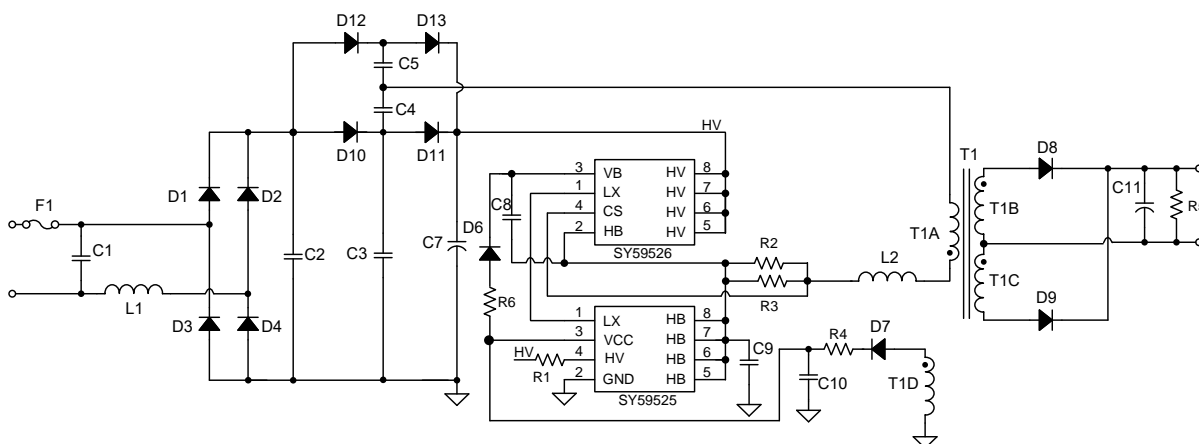

Figure 1a. Typical Application Circuit

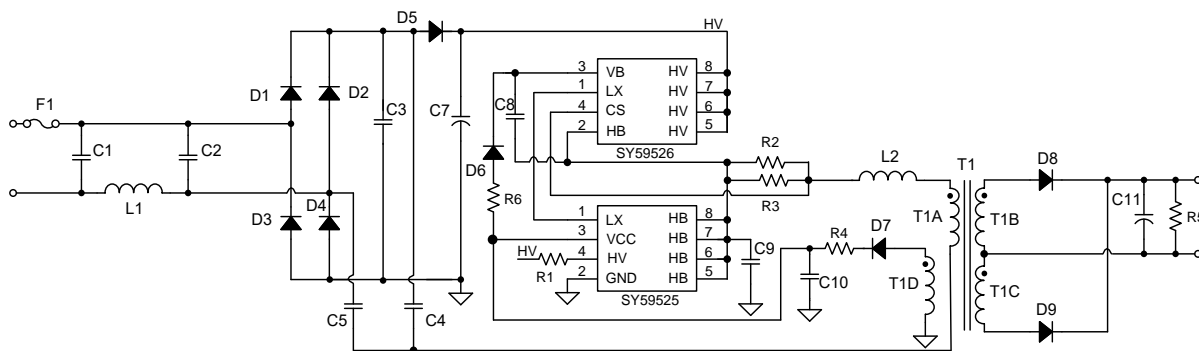

Figure. 1b Typical Application

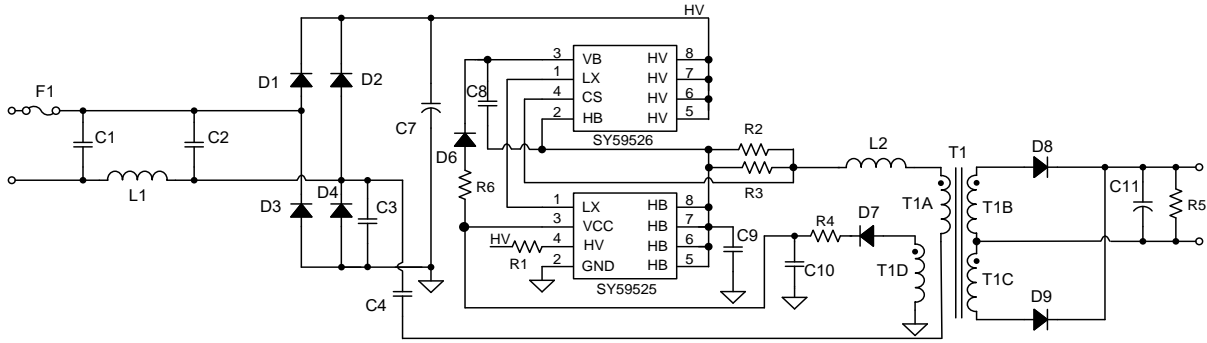

Figure. 1c Typical Application

## Ordering Information

| Ordering Part Number | Package type                           | Top Mark |
|----------------------|--|----------|
| SY59525FAP           | SO8<br>RoHS Compliant and Halogen Free | FLBxyz   |

x=year code, y=week code, z= lot number code

## Pinout (top view)

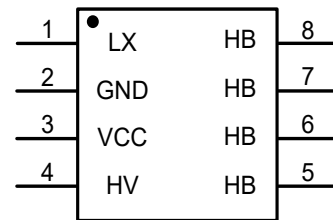

## Pin Description

| Pin No | Pin Name | Pin Description  |
|--------|----------|--|
| 1      | LX       | Low side driver control pin, this pin receives the control signal from SY59526 |
| 2      | GND      | Ground pin for low side circuit.<br>Source of low side internal 650V MOSFET.   |
| 3      | VCC      | Bias supply for low side circuit, LED OVP detection.                           |
| 4      | HV       | HV start pin, HV OVP and HV UVP sense pin.                                     |
| 5-8    | HB       | Drain of internal 650V MOSFET.   |

## Block Diagram



Figure 2. Block Diagram

## Absolute Maximum Ratings

| Parameter(Note 1)                     | Min  | Max | Unit |
|---------------------------------------|------|-----|------|
| HV                                    | -0.3 | 600 | V    |
| VCC                                   | -0.3 | 36  |      |
| LX                                    | -0.6 | 600 |      |
| HB                                    | -0.6 | 650 |      |
| Maximum Junction Temperature          |      | 150 | °C   |
| Lead Temperature (Soldering, 10 sec.) |      | 260 |      |
| Storage Temperature                   | -65  | 150 |      |

## Thermal Information

| Parameter (Note 2)                                   | Min | Max | Unit |
|--|-----|-----|------|
| $\theta_{JA}$ Junction-to-ambient Thermal Resistance |     | 88  | °C/W |
| $\theta_{JC}$ Junction-to-case Thermal Resistance    |     | 45  |      |
| PD Power Dissipation $T_A = 25^\circ\text{C}$        |     | 1.1 | W    |

## Recommended Operating Conditions

| Parameter            | Min  | Max | Unit |
|----------------------|------|-----|------|
| HV                   | 180  | 450 | V    |
| VCC                  | 12.5 | 25  |      |
| LX                   | 0    | 450 |      |
| HB                   | 0    | 450 |      |
| Junction Temperature | -40  | 150 | °C   |
| Ambient Temperature  | -40  | 120 |      |

## Electrical Characteristics

( $V_{VCC}=12V$ (Note 3),  $T_A=25^\circ C$  unless otherwise specified (4))

| Parameter    | Symbol                 | Test conditions | Min                         | Typ  | Max  | Unit     |         |
|--------------|------------------------|-----------------|-----------------------------|------|------|----------|---------|
| Power Supply | VCC Turn-on Threshold  | $V_{VCC\_ON}$   | 10.6                        | 11.4 | 12.2 | V        |         |
|              | VCC Turn-off Threshold | $V_{VCC\_OFF}$  | 7.2                         | 7.9  | 8.6  | V        |         |
|              | VCC OVP Voltage        | $V_{VCC\_OVP}$  | 26.0                        | 27.8 | 29.6 | V        |         |
|              | Quiescent Current      | $I_Q$           | before $V_{VCC\_ON}$        | 190  | 245  | 300      | $\mu A$ |
|              | HV Start up Current    | $I_{ST\_HV}$    |                             | 1.4  | 2.0  | 2.6      | mA      |
| MOSFET       | MOSFET Rdson           | $R_{dson}$      | 0.75                        | 1    | 1.25 | $\Omega$ |         |
|              | Breakdown Voltage      | $V_{BV}$        | $V_{GS}=0, I_{DS}=250\mu A$ | 650  |      |          | V       |
| HV           | HV OVP                 | $V_{HV\_OVP}$   | 465                         | 483  | 500  | V        |         |
|              | HV UVP                 | $V_{HV\_UVP}$   | 160                         | 178  | 196  | V        |         |
| Logic        | MIN_ON                 | $T_{MIN\_ON}$   | 400                         | 525  | 650  | ns       |         |

**Note 1:** Stresses beyond the “Absolute Maximum Ratings” may cause permanent damage to the device. These are stress ratings only. Functional operation of the device at these or any other conditions beyond those indicated in the operational sections of the specification is not implied. Exposure to absolute maximum rating conditions for extended periods may affect device reliability.

**Note 2:**  $\theta_{JA}$  is measured in the natural convection at  $T_A = 25^\circ C$  on a low effective single layer thermal conductivity test board of JEDEC 51-3 thermal measurement standard. Test condition: Device mounted on “2x 2” FR-4 substrate PCB, 2oz copper, with minimum recommended pad on top layer and thermal via to bottom layer ground plane.

**Note 3:** Increase VCC pin voltage gradually higher than  $V_{VCC\_ON}$  voltage to start the IC first, then set VIN to 12V.

**Note 4:** Application test result.

**Note 5:** Guaranteed by design.

## Operation

The SY59525 is the low side LLC controller integrated with a 650V MOSFET, it is used in charge pump PFC application, which is targeting at LED lighting applications. High PF is achieved by inherent PFC function and low LED current ripple is achieved by LLC topology. Single stage structure and primary side regulation save BOM cost a lot.

The SY59525 contains reliable turn on and turn off logic, which can avoid LLC half bridge shoot through and support high switching frequency more than 200kHz. SY59525 also adopts special design to achieve zero voltage overshoot on resonant capacitor at startup. It also uses slope detection function to make sure the valley turn on of MOSFET to achieve higher efficiency.

LLC topology improves efficiency and EMI, furthermore, one external NP0 capacitor can be put between midpoint between LLC half bridge and GND point (or BUS point) to further improve system performance.

The SY59525 provides reliable protections including short circuit protection (SCP), open LED protection (OLP), and E-cap over voltage protection (HV OVP).

The SY59525 is available with SO8 package, and should work with SY59526, which is the high side LLC controller integrated with a 650V MOSFET.

## Applications Information

### Start up

After AC supply or DC BUS is powered on, capacitor  $C_{VCC}$  across VCC and GND pin is charged by internal current source. This current source comes from HV pin, which is connected to  $V_{BUS}$  through one external resistor  $R_{HV\_EXT}$ .

The whole start up process can be divided into 4 sections shown in Fig.3, HO and LO are internal gate of SY59526 and SY59525, respectively.  $t_{STC1}$  is the  $C_{VCC}$  charging up section.  $t_{STD}$  is midpoint HB voltage and HV voltage detecting section, during this time,  $C_{VCC}$  will charge back and forth between  $V_{VCC\_ON}$  and  $V_{VCC\_OFF}$ , until HB voltage is below 6V and HV voltage is lower than HV OVP. The SY59525 provides a constant internal current to pull down HB voltage through LX pin, so when MOSFET of SY59525 is turned on, there won't be large resonant current flowing through resonant capacitor. After the above two conditions are met, SY59525 will exit  $t_{STD}$  stage and enter into  $t_{STC2}$  stage.  $t_{STC2}$  is the  $C_{VCC}$  together with  $C_{VB}$  charging up section, once  $V_{VB}$  reaches  $V_{VB\_ON}$ , internal MOSFET of SY59525 is turned off, switching control starts to work and HV pin stops to provide charge current.  $t_{STO}$  is the output voltage building up section,  $V_{VCC}$  and  $V_{VB}$  will be pulled down by internal consumption current until the auxiliary winding of LLC transformer can supply enough energy to maintain  $V_{VCC}$  above  $V_{VCC\_OFF}$ .

Design of HV pin resistor  $R_{HV\_EXT}$ ,  $C_{VCC}$  and  $C_{VB}$  is not strict, below are some suggestions:

- a) Use  $R_{HV\_EXT}$  smaller than 200kohms, resistance of  $R_{HV\_EXT}$  will influence E-cap over voltage protection (HV OVP).
- b) Use  $C_{VCC}$  larger than 1uF, use  $C_{VB}$  larger than 1uF, there no need to use very large  $C_{VCC}$  or  $C_{VB}$  capacitor, suggest using 2uF  $C_{VCC}$  and 1uF  $C_{VB}$ .
- c) If  $C_{VCC}$  and  $C_{VB}$  are not big enough to build up output voltage at one time, increase  $C_{VCC}$  and  $C_{VB}$ , or check whether the output E-cap is too large.

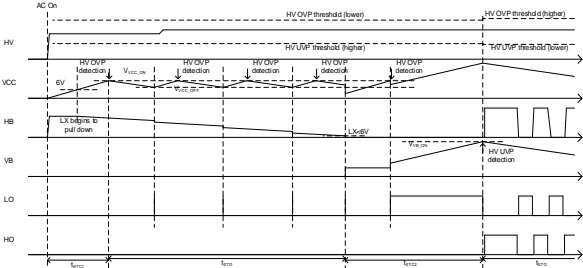

Fig.3 Start up Process of SY59525 and SY59526

After  $V_{VB\_ON}$  and high side MOSFET is turned on, soft start up function works, it prevents resonant current from being too high at start up. Switching frequency is fixed at maximum switching frequency  $f_{SW\_MAX}$  during the first few resonant periods.

### Shut down

After AC supply or DC BUS is powered off, LLC still works for a while to consume the energy stored in input E-cap. During this time, auxiliary winding can still provide stable VCC voltage so SY59525 and SY59526 can continue with the internal working logic. Once HV pin voltage reaches E-cap under voltage protection (HV UVP), SY59525 will keep internal MOSFET off and SY59526 will turn off its internal MOSFET soon. Once high side and low side MOSFET are turned off,  $C_{VCC}$  and  $C_{VB}$  will discharge, discharge current of  $C_{VCC}$  is quiescent current of SY59525 and discharge current of  $C_{VB}$  is constant 6mA. Usually,  $V_{VB}$  reaches  $V_{VB\_OFF}$  earlier than  $V_{VCC}$  reaches  $V_{VCC\_OFF}$ . When  $V_{VB}$  reaches  $V_{VB\_OFF}$ , 6mA discharge current will be removed. When  $V_{VCC}$  reaches  $V_{VCC\_OFF}$ , SY59525 will restart and HV pin starts to provide charge current.

To avoid flashback after shut down, SY59525 adopts a hysteresis loop at HV UVP threshold, the lower threshold is used at normal shut down process, and the higher threshold is used at start up process. After  $V_{VB}$  reaches  $V_{VB\_ON}$ , SY59525 detects HV voltage to determine whether it's enough. So after system shut down, HV voltage needs to be higher to restart up successfully and flashback is avoided.

## Short LED protection (SLP), open LED protection (OLP), E-cap over voltage protection (HV OVP)

SLP: When output is in short circuit condition, auxiliary winding cannot provide charge current to  $C_{VCC}$ , so  $C_{VCC}$  and  $C_{VB}$  will discharge synchronously by operating current consumption. Once  $V_{VB}$  reaches  $V_{VB\_OFF}$ , SY59526 will turn off MOSFET and pull down LX pin from VB to HB. Later when  $V_{VCC}$  reaches  $V_{VCC\_OFF}$ , SY59525 begins to restart.

OLP: Output voltage is reflected by auxiliary winding of LLC transformer,  $V_{VCC}$  is proportional to output voltage. When the load is null, secondary side current of LLC transformer will charge output E-cap continuously and  $V_{VCC}$  will increase. Once  $V_{VCC}$  reaches  $V_{VCC\_OVP}$ , SY59525 will enter fault state and system will restart later. So the turns of auxiliary winding  $N_{AUX}$  and secondary winding  $N_S$  will influence the output voltage  $V_{O\_OLP}$  in OLP situation,  $V_D$  is the voltage drop of rectifier diode, as shown in Fig.4.

$$V_{O\_OLP} = \frac{N_S}{N_{AUX}} \times (V_{VCC\_OVP} + V_D) - V_D$$

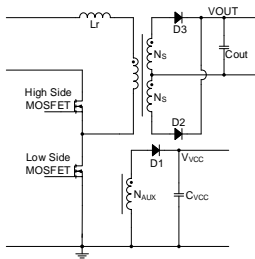

Fig.4 OLP Principle of SY59525

HV OVP: When AC supply or DC BUS is too high, or surge comes, or in output short circuit condition,  $V_{BUS}$  may be over voltage, which will lead to the failure of input E-cap or internal MOSFET in SY59525 and SY59526. There is a resistor divider composed of one external HV pin resistor  $R_{HV\_EXT}$  and two internal HV pin resistors. Two internal HV resistors are  $R_{HV\_H}$  and  $R_{HV\_L}$ , their resistance are  $4M\Omega$  and  $10k\Omega$ . As shown in Fig.5, voltage across  $R_{HV\_L}$  is used to compare with  $V_{BUS\_OVP}$ , the actual  $V_{BUS}$  in HV OVP can be calculated as below:

$$V_{HV\_OVP} = \frac{R_{HV\_EXT} + R_{HV\_H} + R_{HV\_L}}{R_{HV\_L}} \times V_{BUS\_OVP}$$

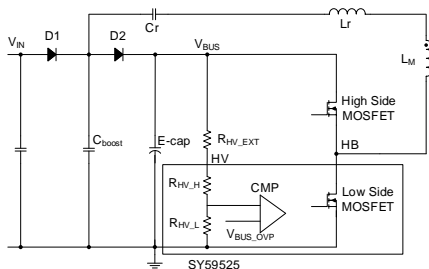

Fig.5 HV OVP Principle of SY59525

$R_{HV\_H}$ ,  $R_{HV\_L}$  and  $V_{BUS\_OVP}$  all influence  $V_{HV\_OVP}$ , and  $V_{HV\_OVP}$  is the key parameter that affect the system, so  $V_{HV\_OVP}$  with  $0\Omega$   $R_{HV\_EXT}$  is provided in electrical characteristics table. Besides,  $R_{HV\_EXT}$  can adjust  $V_{HV\_OVP}$  within a certain range.

The SY59525 adopts a hysteresis loop at HV OVP threshold, the lower threshold is only used during  $t_{STD}$  at start up process. After  $V_{VB}$  reaches  $V_{VB\_ON}$ , HV OVP threshold turns to the higher one. This hysteresis loop is used to avoid the system locked in the HV OVP state at some very special situations.

## Magnetic Element Design

According to the design table, calculate the resonant inductor, resonant capacitor and boost capacitor. Left part of design table is one standard design with good performance, this topology has good normalized property, which means the resonant parameters is related to output current  $I_o$ , resonant frequency  $f_r$  and maximum output voltage  $V_{O\_MAX}$ .

### Inductor

System works in LC resonant condition, the peak value and RMS value of resonant current can be calculated:

$$I_{r\_peak} = 2 \times I_o / N_{ps}$$

$$I_{RMS} = \frac{I_{r\_peak}}{\sqrt{3}}$$

Usually select  $B_{max\_ind}$  between 0.2 and 0.3, so turn number of inductor can be calculated:

$$n_{ind} = \frac{I_{r\_peak} \times L_r}{A_{e\_ind} \times B_{max\_ind}}$$

It's recommended to use litz wire for lower temperature rise. Current density  $j_{ind}$  is selected at  $8A/mm^2$ , so the number of 0.1mm enameled wire  $n_{litz}$  can be calculated:

$$n_{litz} = \frac{4 \times I_{RMS}}{\pi \times j_{ind} \times 0.1^2}$$

### Transformer

RMS value of primary winding current is the same as inductor, so the wire diameters of primary and secondary winding are easy to get. Usually select  $B_{max\_trans}$  as 0.3, and the turn number of primary winding can be calculated:

$$n_{p\_trans} = \frac{V_{O\_MAX} \times n_{ps}}{4 \times f_r \times B_{max\_trans} \times A_{e\_trans}}$$

$$n_{s\_trans} = \frac{n_{s\_trans}}{n_{ps}}$$

The auxiliary winding should satisfy the following conditions:

$$V_{O\_OLP} + V_D = \frac{N_S}{N_{AUX}} \times (V_{VCC\_OVP} + V_D)$$

$$(V_{O\_MIN} + V_D) \times \frac{N_{AUX}}{N_S} - V_D > 13V$$

No air gap is required for transformer cores, large inductance of primary winding is needed, it's suggested that the ratio of inductance of primary winding and resonant inductor be larger than 3. If the ratio is small, it needs to change the bobbin and core size of inductor or transformer.

### Magnetic Integrated Design

It's recommended to use magnetic integrated design for better efficiency and power density. In this design, leakage inductance of transformer primary winding is used as resonant inductor, so the key of magnetic integrated design is the control of leakage inductance. Fig.6 shows the structure of magnetic integrated transformer, primary and secondary windings are placed at left side and right side, respectively, between them is a big gap for larger leakage inductance. Leakage inductance mainly depends on the turn number of primary winding, bobbin size and the big gap in the middle. Red line represents the leakage inductance of primary winding, which is equivalent to the role of resonant inductor, and the green line represents the transformer excitation loop.

In magnetic integrated design, usually it's no need to consider the inductance ratio between primary winding and resonant inductor, because the bobbin size of transformer becomes larger than discrete design, the excitation inductance is much larger.

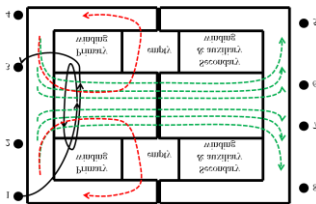

Fig.6 Structure of Magnetic Integrated Transformer

### Layout

(a) Because of the charge pump structure, it's not necessary to put the input E-cap close to bridge rectifier. Make sure the loop composed of input E-cap, HV of SY59526, HB of SY59526, HB of SY59525 and GND of SY59525 to be as small as possible.

(b) The circuit loop of CS sampling should be kept small.

(c) The  $C_{VB}$  charge loop should be kept small,  $C_{VB}$  should be put near SY59526.

(d) The  $C_{VCC}$  and  $N_{AUX}$  charging loop should be kept small,  $C_{VCC}$  should be put near SY59525.

(e) Not recommend to put high voltage track under low voltage components, such as HV and LX.

(f) Recommend to use a high voltage MLCC in parallel with input E-cap, recommend to connect the core of inductor to low frequency input line after filter.

(g) The connection of ground is recommended as:

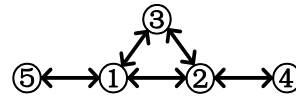

Ground ①: ground of input E-cap

Ground ②: ground of SY59525 and  $C_{VCC}$

Ground ③: ground of external high voltage NP0 MLCC

Ground ④: ground of auxiliary winding

Ground ⑤: ground of bridge rectifier and  $C_{boost}$

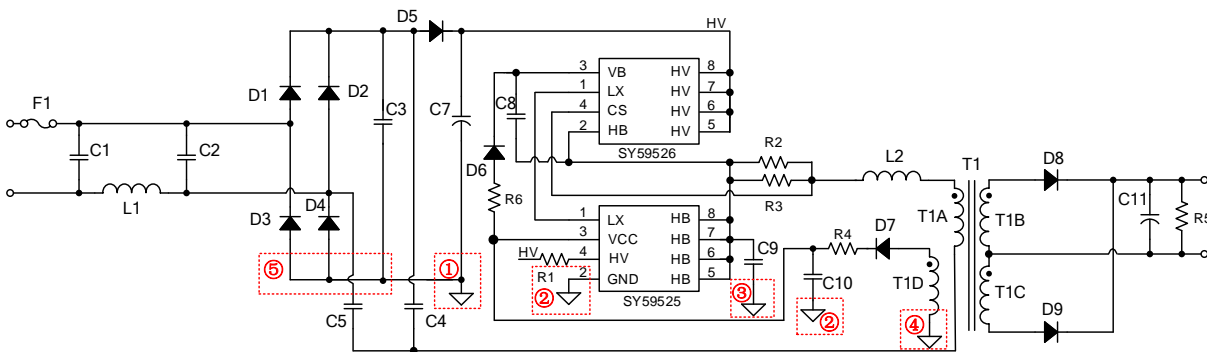

Fig.7 Ground Connection Recommended

## Design Example

Table 1 and table 2 show the key parameters of standard design in design table and parameters defined by the customer, respectively. The relationship between them is also provided.

Table 1 Key Parameters of Standard Design

| System Conditions        |                 |         |
|--------------------------|-----------------|---------|
| Maximum Output Voltage   | $V_{O\_MAX\_S}$ | 42V     |
| Output Current           | $I_{O\_S}$      | 1A      |
| Output Diode Drop        | $V_{DF\_S}$     | 1.3V    |
| Main Resonant Frequency  | $f_{r\_S}$      | 52.5kHz |
| Key Parameters           |                 |         |
| Turns Ratio              | $N_{PS\_S}$     | 1.75    |
| Sampling Resistor        | $R_{CS\_S}$     | 0.26Ω   |
| Resonant Inductor        | $L_{r\_S}$      | 700uH   |
| Main Resonant Capacitor  | $C_{r\_S}$      | 27nF    |
| Minor Resonant Capacitor | $C_{r2\_S}$     | 3.3nF   |
| Boost Capacitor          | $C_{boost\_S}$  | 15nF    |
| Input E-cap              | $C_{in\_S}$     | 15uF    |

Table 2 Parameters Defined by Customer

| System Conditions        |                 |        |
|--------------------------|-----------------|--------|
| Maximum Output Voltage   | $V_{O\_MAX\_C}$ | 40V    |
| Output Current           | $I_{O\_C}$      | 0.8A   |
| Output Diode Drop        | $V_{DF\_C}$     | 1.3V   |
| Main Resonant Frequency  | $f_{r\_C}$      | 70kHz  |
| Key Parameters           |                 |        |
| Turns Ratio              | $N_{PS\_C}$     | 1.83   |
| Sampling Resistor        | $R_{CS\_C}$     | 0.34Ω  |
| Resonant Inductor        | $L_{r\_C}$      | 689uH  |
| Main Resonant Capacitor  | $C_{r\_C}$      | 15.4nF |
| Minor Resonant Capacitor | $C_{r2\_C}$     | 1.9nF  |
| Boost Capacitor          | $C_{boost\_C}$  | 8.6nF  |
| Input E-cap              | $C_{in\_C}$     | 11uF   |

$$N_{PS\_C} = N_{PS\_S} \times \frac{V_{O\_MAX\_S} + V_{DF\_S}}{V_{O\_MAX\_C} + V_{DF\_C}}$$

$$R_{CS\_C} = 0.15 \times \frac{N_{PS\_C}}{I_{O\_C}}$$

$$L_{r\_C} = L_{r\_S} \times \frac{V_{O\_MAX\_S} \times I_{O\_S} \times f_{r\_S}}{V_{O\_MAX\_C} \times I_{O\_C} \times f_{r\_C}}$$

$$C_{r\_C} = C_{r\_S} \times \frac{V_{O\_MAX\_C} \times I_{O\_C} \times f_{r\_S}}{V_{O\_MAX\_S} \times I_{O\_S} \times f_{r\_C}}$$

$$C_{r2\_C} = C_{r2\_S} \times \frac{V_{O\_MAX\_C} \times I_{O\_C} \times f_{r\_S}}{V_{O\_MAX\_S} \times I_{O\_S} \times f_{r\_C}}$$

$$C_{boost\_C} = C_{boost\_S} \times \frac{V_{O\_MAX\_C} \times I_{O\_C} \times f_{r\_S}}{V_{O\_MAX\_S} \times I_{O\_S} \times f_{r\_C}}$$

$$C_{in\_C} = C_{in\_S} \times \frac{V_{O\_MAX\_C} \times I_{O\_C}}{V_{O\_MAX\_S} \times I_{O\_S}}$$

$V_{O\_MAX\_C}$ ,  $I_{O\_C}$ ,  $V_{DF\_C}$  and  $f_{r\_C}$  are defined by customer, and other key parameters will be calculated according to the above normalization formula.

# SO8 Package outline & PCB layout design

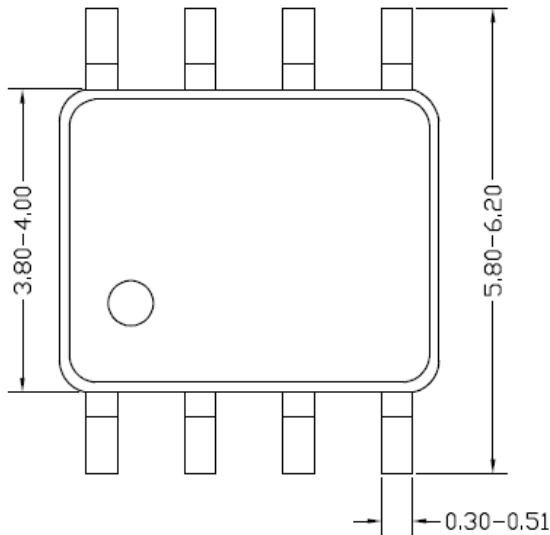

**Top view**

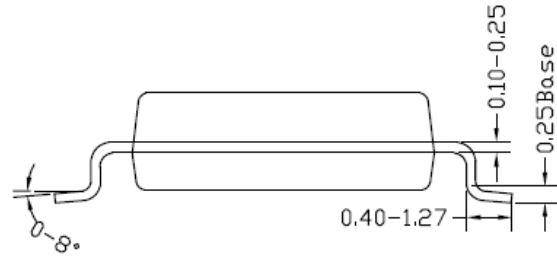

**Side view**

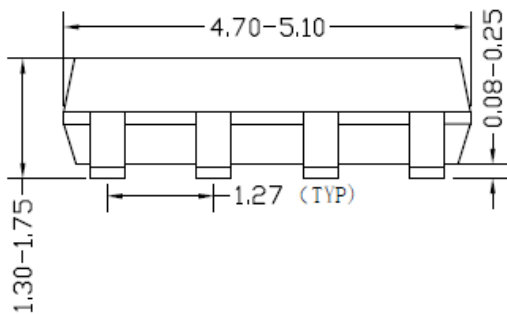

**Front view**

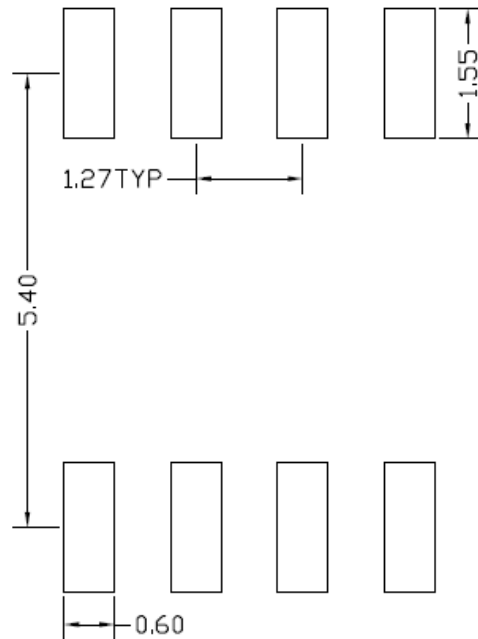

**Recommended Pad Layout  
(Reference only)**

**Notes: All dimension in millimeter and exclude mold flash & metal burr.**

## Taping & Reel Specification

### 1. Taping orientation for packages (SO8)

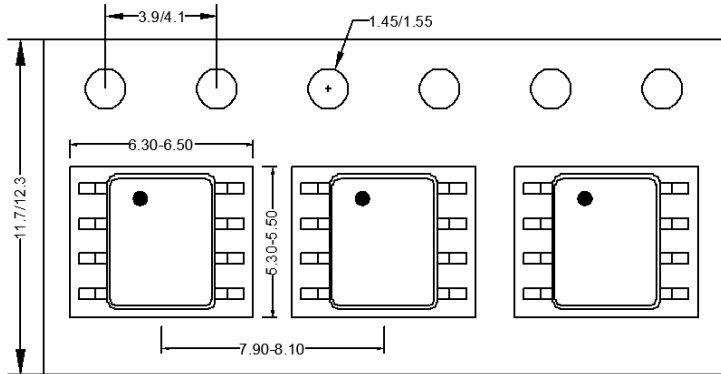

Feeding direction →

### 2. Carrier Tape & Reel specification for packages

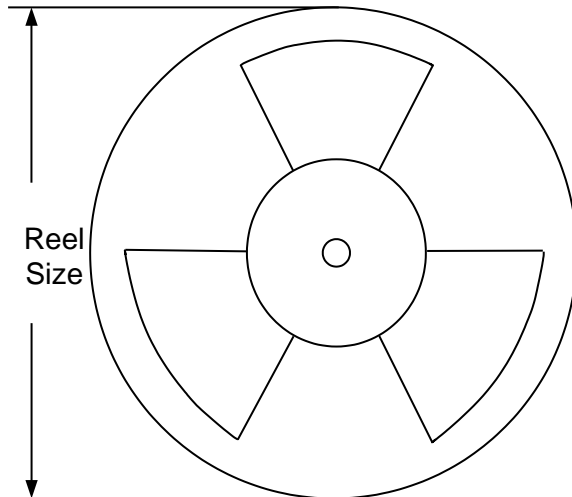

| Package type | Tape width (mm) | Pocket pitch(mm) | Reel size (Inch) | Trailer length(mm) | Leader length (mm) | Qty per reel |
|--------------|-----------------|------------------|------------------|--------------------|--------------------|--------------|
| SO8          | 12              | 8                | 13"              | 400                | 400                | 2500         |

## Revision History

The revision history provided is for informational purpose only and is believed to be accurate, however, not warranted. Please make sure that you have the latest revision.

| <b>Date</b>       | <b>Revision</b> | <b>Change</b>   |
|-------------------|-----------------|-----------------|
| December 11, 2024 | Revision 1.0    | Initial Release |

**IMPORTANT NOTICE**

1. **Right to make changes.** Silergy and its subsidiaries (hereafter Silergy) reserve the right to change any information published in this document, including but not limited to circuitry, specification and/or product design, manufacturing or descriptions, at any time and without notice. This document supersedes and replaces all information supplied prior to the publication hereof. Buyers should obtain the latest relevant information before placing orders and should verify that such information is current and complete. All semiconductor products are sold subject to Silergy's standard terms and conditions of sale.

2. **Applications.** Application examples that are described herein for any of these products are for illustrative purposes only. Silergy makes no representation or warranty that such applications will be suitable for the specified use without further testing or modification. Buyers are responsible for the design and operation of their applications and products using Silergy products. Silergy or its subsidiaries assume no liability for any application assistance or designs of customer products. It is customer's sole responsibility to determine whether the Silergy product is suitable and fit for the customer's applications and products planned. To minimize the risks associated with customer's products and applications, customer should provide adequate design and operating safeguards. Customer represents and agrees that it has all the necessary expertise to create and implement safeguards which anticipate dangerous consequences of failures, monitor failures and their consequences, lessen the likelihood of failures that might cause harm and take appropriate remedial actions. Silergy assumes no liability related to any default, damage, costs or problem in the customer's applications or products, or the application or use by customer's third-party buyers. Customer will fully indemnify Silergy, its subsidiaries, and their representatives against any damages arising out of the use of any Silergy components in safety-critical applications. It is also buyers' sole responsibility to warrant and guarantee that any intellectual property rights of a third party are not infringed upon when integrating Silergy products into any application. Silergy assumes no responsibility for any said applications or for any use of any circuitry other than circuitry entirely embodied in a Silergy product.

3. **Limited warranty and liability.** Information furnished by Silergy in this document is believed to be accurate and reliable. However, Silergy makes no representation or warranty, expressed or implied, as to the accuracy or completeness of such information and shall have no liability for the consequences of use of such information. In no event shall Silergy be liable for any indirect, incidental, punitive, special or consequential damages, including but not limited to lost profits, lost savings, business interruption, costs related to the removal or replacement of any products or rework charges, whether or not such damages are based on tort or negligence, warranty, breach of contract or any other legal theory. Notwithstanding any damages that customer might incur for any reason whatsoever, Silergy' aggregate and cumulative liability towards customer for the products described herein shall be limited in accordance with the Standard Terms and Conditions of Sale of Silergy.

4. **Suitability for use.** Customer acknowledges and agrees that it is solely responsible for compliance with all legal, regulatory and safety-related requirements concerning its products, and any use of Silergy components in its applications, notwithstanding any applications-related information or support that may be provided by Silergy. Silergy products are not designed, authorized or warranted to be suitable for use in life support, life-critical or safety-critical systems or equipment, nor in applications where failure or malfunction of an Silergy product can reasonably be expected to result in personal injury, death or severe property or environmental damage. Silergy assumes no liability for inclusion and/or use of Silergy products in such equipment or applications and therefore such inclusion and/or use is at the customer's own risk.

5. **Terms and conditions of commercial sale.** Silergy products are sold subject to the standard terms and conditions of commercial sale, as published at <http://www.silergy.com/stdterms>, unless otherwise agreed in a valid written individual agreement specifically agreed to in writing by an authorized officer of Silergy. In case an individual agreement is concluded only the terms and conditions of the respective agreement shall apply. Silergy hereby expressly objects to and denies the application of any customer's general terms and conditions with regard to the purchase of Silergy products by the customer.

6. **No offer to sell or license.** Nothing in this document may be interpreted or construed as an offer to sell products that is open for acceptance or the grant, conveyance or implication of any license under any copyrights, patents or other industrial or intellectual property rights. Silergy makes no representation or warranty that any license, either express or implied, is granted under any patent right, copyright, mask work right, or other intellectual property right. Information published by Silergy regarding third-party products or services does not constitute a license to use such products or services or a warranty or endorsement thereof. Use of such information may require a license from a third party under the patents or other intellectual property of the third party, or a license from Silergy under the patents or other intellectual property of Silergy.

For more information, please visit: [www.silergy.com](http://www.silergy.com)

©2024 Silergy Corp.

All Rights Reserved.